

ITEM	D/S	PART NO.	QTY	DESCRIPTION	MAT'L. GR.	EST. WT.	PAINT	CODE
1	B	05286001910	1	FORMED PL 1/4" X 29 1/16" LG -LH	A36	11	I	-
2	B	05286001909	1	FORMED PL 1/4" X 32 1/16" LG -RH	A36	24	I	-
3	B	05286001908	1	FORMED PL 1/4" X 32 1/16" LG -LH	A36	24	I	-
4	B	1009004098	2	KNEE BRACE GUSSET 1/4" PL	A36	3	I	-
5	-	UBLTG8625	1	8" U-BOLT W/ NUTS HDG	A36	2	N	-
6	B	05286001907	2	L3" X 3" X 1/4" X 37 1/2" LG	A36	15	I	-
7	B	05286001911	1	FORMED PL 1/4" X 29 1/16" LG -RH	A36	11	I	-
8	B	05286001904	1	FORMED PL 1/4" X 21 11/16" LG	A36	8	I	-
9	-	WSHFG0500	3	WASHER 1/2" FLAT HDG	HDG	0	N	-
10	-	BLTFJSC105001500	9	BOLT 1/2" X 1 1/2" FN PC JS1000 GR8	GR 8	0	N	-
11	-	WSHFJS10500F436	31	WASHER FLAT 1/2" JS1000	F436	0	N	-
12	-	NUTHJS10500	31	NUT HEX 1/2" JS1000 GR5	GR 5	0	N	-
13	-	BLTSQJS105001500	22	BOLT 1/2" X 1 1/2" SQ. HD. JS1000 GR8	GR 8	0	N	-
14	-	NUTC5022	9	NUT COVER EXTERIOR COBALT BLUE	-	-	-	-

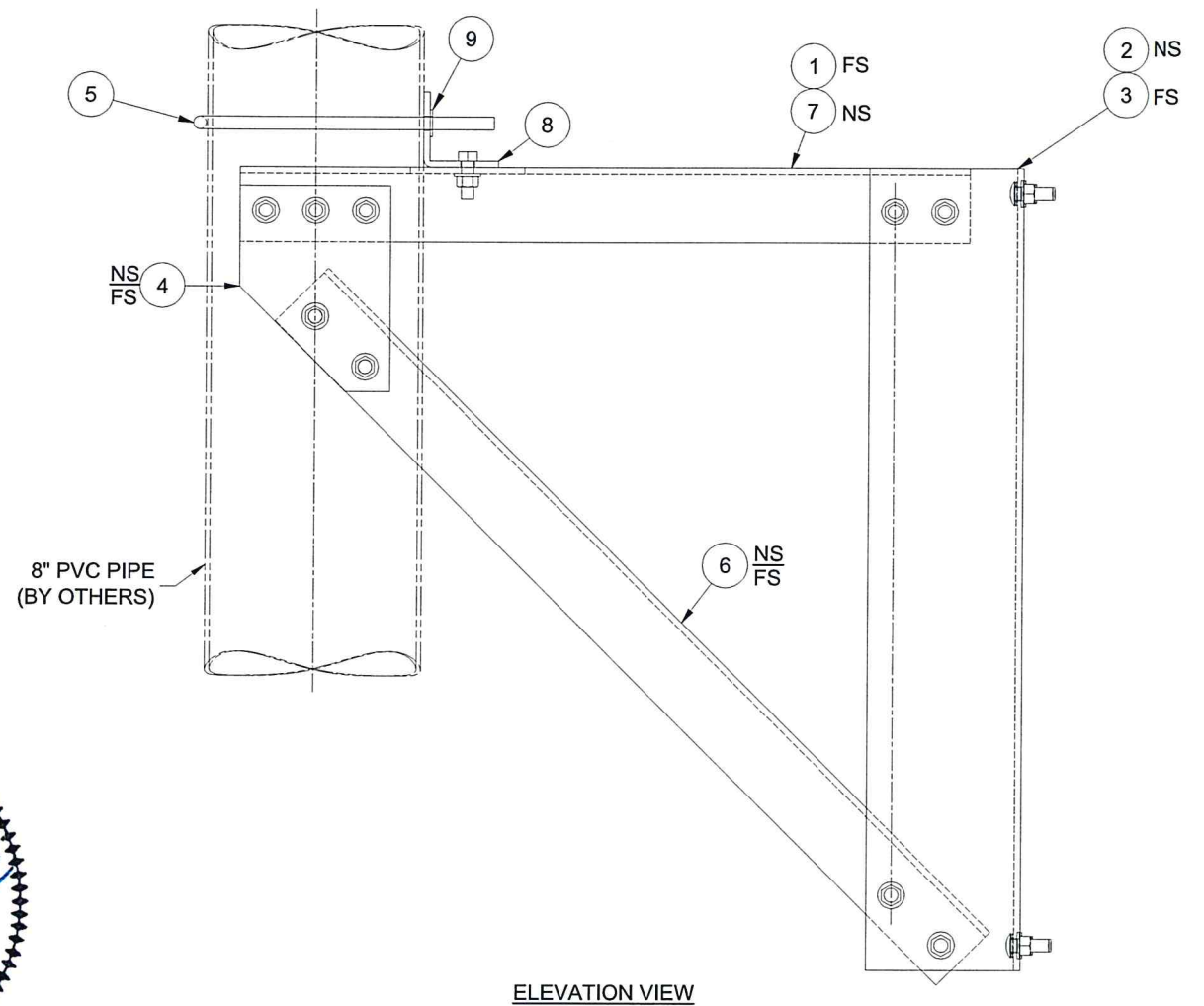
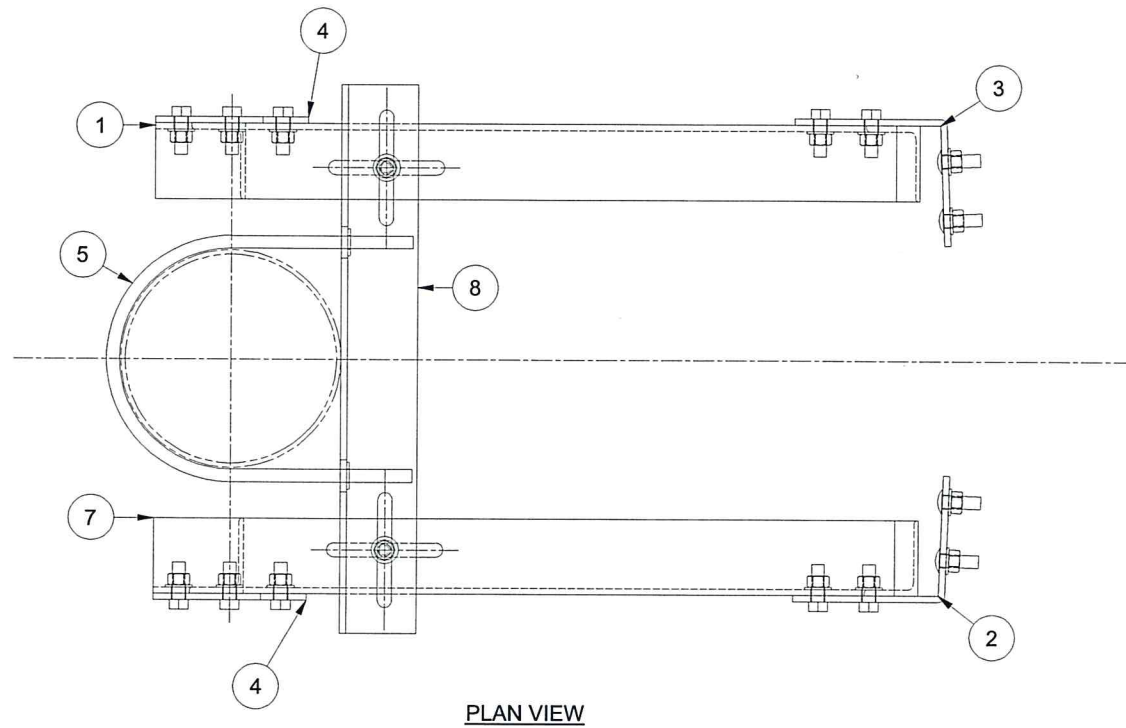

Kevin W Sheddrick, PE  
2016.01.11 13:26:25 -06'00'

NOTE: INSTALL PUSH CAPS ON ALL EXTERIOR NUTS. NOTE: FILL PUSH CAPS HALF FULL OF SEALANT BEFORE INSTALLING NOTE: USE FN PC BOLTS FOR BRKT TO SIDEWALL CONNECTIONS.

TOTAL WT: 116		PARENT: ---		THE INFORMATION ON THIS DOCUMENT IS CONFIDENTIAL PROPERTY OF TANK CONNECTION AND/OR ITS AFFILIATES. ANY OTHER USE, RETENTION, DISSEMINATION, FORWARDING, PRINTING OR COPYING OF THIS DOCUMENT TO UNAUTHORIZED PARTIES IS STRICTLY PROHIBITED, WITHOUT THE EXPRESSED WRITTEN CONSENT OF TANK MANUFACTURER.				<b>CERTIFIED: APPROVED FOR CONSTRUCTION</b>	
<b>***DO NOT SCALE***</b> DRAWING IN INCHES ANSI/ASME Y14.1 STANDARDS		<b>TOLERANCES UNLESS OTHERWISE NOTED</b> ANGULAR DEVIATION $X = \pm 1.0^\circ / X.X = \pm 0.5^\circ$		PERMISSIBLE DEVIATION NOMINAL LENGTH IN INCHES 0 - 4"    4" - 48"    48" - 130"    130" - 240"    240"+		LINEAR TOLERANCE: 1/32"    1/16"    5/32"    1/8"    3/16"		HOLE TO HOLE TOLERANCE: 1/32"    1/32"    1/32"    1/16"    1/16"	
		3RD ANGLE PROJECTION		0    RELEASED FOR FABRICATION    12/11/2015    CAS    JBB		INTERIOR 8" PIPE SUPPORT BRACKET		PROJ #    05286    JOB #    001	
DWG #    KBA05286001		DWG SIZE: B    SCALE: NTS		REV    REVISION DESCRIPTION    DATE    DRAWN BY    CHECKED BY		0    RELEASED FOR FABRICATION    12/11/2015    CAS    JBB		DWG #    KBA05286001	